

REACTOR TYPE FURNACES

Max. Temperature 1200 °C – Vertical & Horizontal mounting Orientation

Split Tube models

Model Family: RCT-BW1-O-1200

Description.

RCT-BW1-O-1200 furnace family was designed to provide a flexible and functional laboratory solution. The hinged construction offer convenience to the reactor installation and setting up access and provide a solution in situations where reactor is permanently connected to the processes manifold where furnace could literally wrapped around it

This model family is suitable for harsh and demanding thermal processes environment up to **1200 °C**. The furnace can operate in a vertical, horizontal or any intermediate angle position with no restriction.

The hot zone is constructed from high resistance, low porosity ceramic materials. The low density fibrous back insulation allows for rapid heat up and cool down rates while, in conjunction with the double wall design, minimizing energy consumption. The semi-exposed dense structure of metallic resistance (FeCrAl) yielding in extremely uniform thermal distribution profiles. Combined with suitable high heat resistant tube this furnace model is an excellent choice for a number of demanding processes, like combustion-incineration, metal melting under inert or hydrogen atmosphere, fluidized or fixed bed reactions, catalyst testing etc.

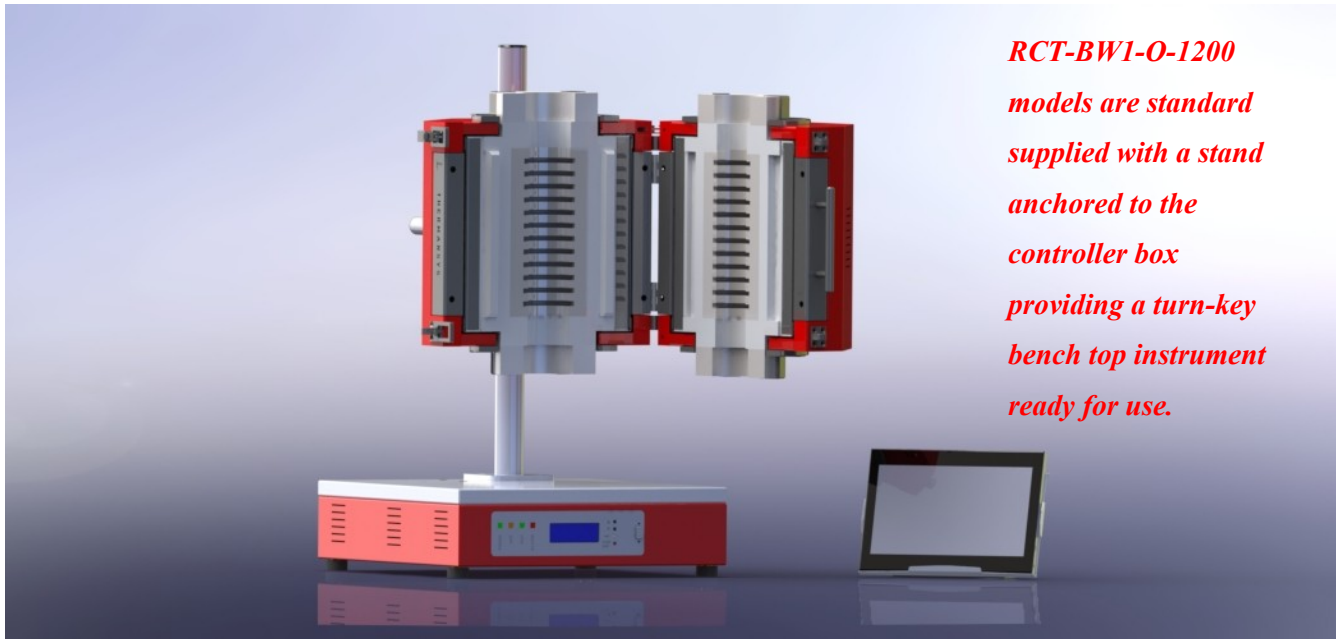

RCT-BW1-O-1200 models are standard supplied with a stand anchored to the controller box providing a turn-key bench top instrument ready for use.

Key features.

- Control strategy by Thermansys PCC (Power Consistent Control) insures compliance with EMC standards.
- Modern double wall construction keeps external surfaces temperature low, emphasizing in operator safety.
- Ergonomic design with no protruding edges, combines stainless steel parts with painted finish parts for an improved aesthetic result.
- Conduits connecting the furnace body with the controller ending in detachable connectors allowing easy movement
- Split tube, hinged design
- Mounting mechanism allowing unlimited angles of mounting orientation
- Touch screen computer running the user friendly, [PYROLOGISM](#) 2.0 software.
- 3 channel thermocouple inputs software configurable available (B, K, R, S type).
- Power and true RMS Current measuring circuits.
- Heater failure, open control thermocouple detection alarms and interlocks.
- Stand alone over-temperature limiter (Watchdog) with manual reset in accordance with EN 60519-2 to protect the heater and load.
- Accurate and uniform temperature profiles.

Contact details:

Ath. Stagiriti 7- Pilea, Thessaloniki Greece, 55534
 tel. 0030 2310 942346, fax. 0030 2310 942336
 e-mail: info@thermansys.com
www.thermansys.com

Information and data contained in this document was considered correct at the time of publication.
 Thermansys® is reserving the right to make modifications as a result of design improvements.

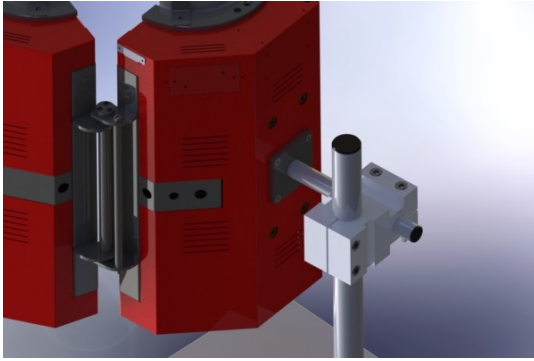

- A special mechanism allows unlimited angles of mounting orientation and height adjustment.
- Robust hinge mechanism with bearings.
- The furnace main body can be released from the main controller, with or without the mounting mechanism, and placed at the best position serving the process.

PYROCONTROLLER SYSTEM

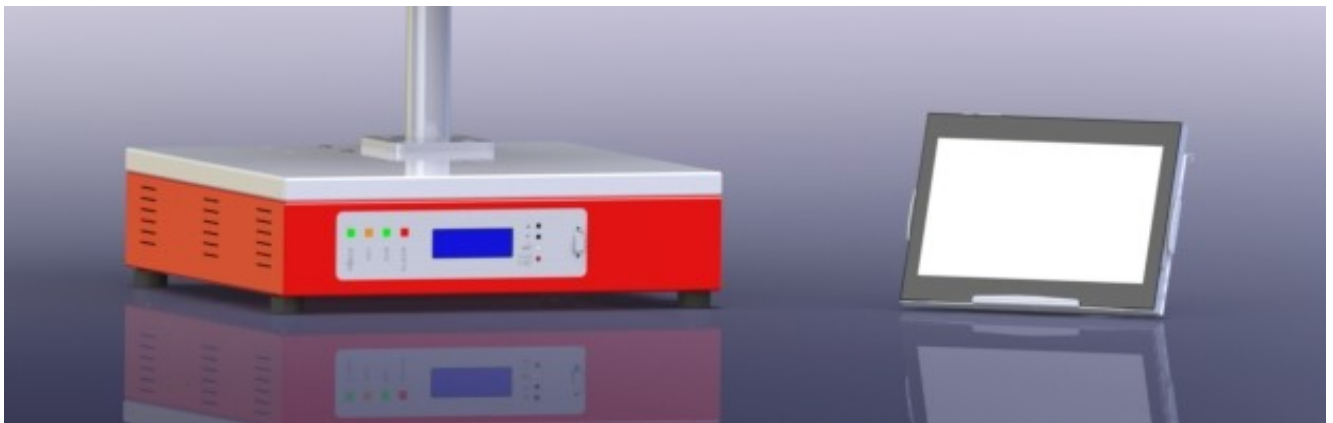

Standard equipped with a Digital LCD display temperature controller providing 15 step programming with 1 program storage.

Optionally equipped with a sophisticated, remote, touch screen, running the specially designed PYROLOGISM 2.0 software, provides a really unique and friendly, windows oriented architecture interface with multiple, advanced features and peripherals.

PYROLOGISM 2.0 control and monitoring software.

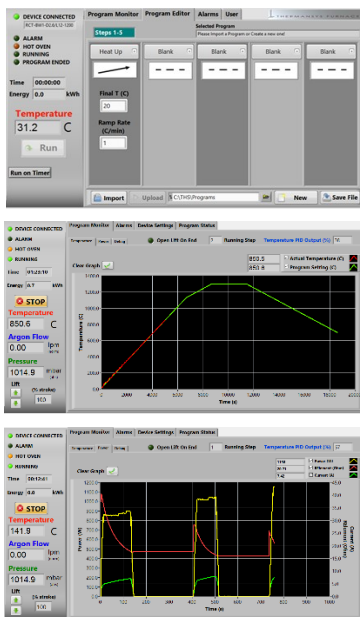

- Programming with up to 15 Temperature programming steps. Graphical inspection.
- Storage and reload of unlimited number of distinct programs.
- Continuous monitoring of control Temperature and In depended thermocouple inputs.
- Real time graphical presentation of executed program data.
- Data file creation for all executed programs. Saves all data on local memory.
- Real time actual Power (W) and totalized Energy (kWh) chart.
- Alarm and event message tab. Overheating Alarm, open Thermocouple Alarm, Heater Alarm.
- Programmable over temperature limiter monitor/configuration.
- Remote control through network connection.
- Power Safe, Uninterrupted Power Supply backup configuration. Recovers program after short term power failure.
- User Thermocouple configuration page
- Run on timer function

Contact details:

Ath. Stagiriti 7- Pilea, Thessaloniki Greece, 55534
 tel. 0030 2310 942346, fax. 0030 2310 942336
 e-mail: info@thermansys.com
www.thermansys.com

Information and data contained in this document was considered correct at the time of publication. Thermansys® is reserving the right to make modifications as a result of design improvements.

Accessories Available.

Work-tubes.

- Dense ceramic Alumina work-tubes for the highest temperature applications.
- Quartz work-tubes for maximum chemical inertia and for aggressive environments to work under vacuum or low pressure conditions up to 1100 °C continuously.
- KANTHAL® APM™/APMT metallic (FeCrAl based) work-tubes to serve under vacuum or pressure up to 1250 °C.



Model shown RCT-BW1-T-D5.2L23-1200 with optional mounting stand and electronically actuated Lifter.

Mounting Stands.

Assembled and constructed using BOSCH-REXROTH® structural profile systems these stands provide the ideal solution for vertical furnace stand alone positioning plus reactor and instrumentation mounting. Using the commercially available accessories, tubing and cable routing is easy and professionally accomplished.



Stand equipped with electronically actuated Lifter allows furnace body up/down linear motion.

Motion is manually actuated through side keyboard and through PYROLOGISM software.

Automated motion programming is possible through PYROLOGISM

End Gas Sealing Flanges and Manifolds.

THERMANSYS® is providing work-tube End Gas Sealing Flanges for vacuum or pressure conditions.

These flanges are provided with Main Port either with hydraulic thread port or with Clamp Flange (CF) port for gases inlet/outlet-connection to the tubing network. Cooling fluid recirculation compartment is standard and is removable. Up to four peripheral threads are available serving as ports for instrumentation mounting (e.g thermocouples, pressure sensors).

Versions with Clamp Flange (CF) port design provide quick-open loading port and optionally a quartz sight window.

THERMANSYS® End Gas Sealing Flanges are supplied for work tubes diameters from 1'' to 3''. Their design allows use with tubes having diameter tolerance $\pm 10\%$.

Standard versions material of construction is Stainless Steel ASME 304. Optionally for corrosive applications Stainless Steel ASME 316 is available and Aluminum for a light weight solution (recommended for thin wall Quartz tube reactors).

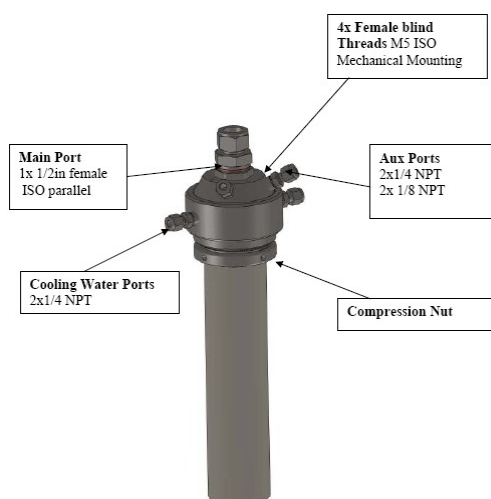

Please contact our sales team for detailed information and ordering on our Tube Furnace Accessories optional equipment

Contact details:

Ath. Stagiriti 7- Pilea, Thessaloniki Greece, 55534
tel. 0030 2310 942346, fax. 0030 2310 942336
e-mail: info@thermansys.com
www.thermansys.com

Information and data contained in this document was considered correct at the time of publication.

Thermansys® is reserving the right to make modifications as a result of design improvements.

Technical Drawings.

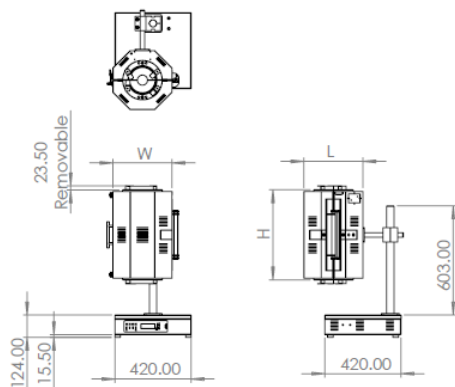

Drawing 1. RCT-BW1-O-1200 Furnace Body

Specifications and Ordering Information.

Standard features:

- Maximum continuous temperature 1200 °C.
- Operating Power: 220 /240VAC – 50/60Hz.
- S type embedded thermocouples
- Temperature control accuracy ± 1 °C.
- Semi-Exposed resistors type.
- Thermocouple inputs: 3 chan. - B, K, R, S type -software configurable Typical accuracy $\pm 0.2\%$ f.s @ 25 resolution 0.1 °C.
- LCD display temperature controller providing 15 step programming with 1 program storage.

Optional features:

- Remote, touch screen temperature controller, running the specially designed PYROLOGISM 2.0 software on a 10.0in Tablet PC
Add suffix _TSC
- Programmable stand-alone over-temperature limiter (Watchdog) with manual reset in accordance with EN 60519-2 to protect the heater and load,
Add suffix _WD
- UPS (Uninterrupted Power Supply) that will keep system alive for short periods of power failure and restore program after power recovery
Add suffix _UPS

CE Certified. Compliant with **Low Voltage Directive 2006/95/EC** (harmonized referenced standard EN 61010-1: 2001 and EN 61010-2-010:2003) and **EMC Directive 2004/108/EC** (harmonized referenced standard EN 61326-1:2006).

TABLE 1. RCT-BW1-1200 Models

Model Part Number RCT-BW1-O...	Max. Cont. Temp. °C x Heat up time* min	Furnace I.D. mm x Heated length mm x Total length mm	Uniform Temp. length mm ± 10 °C approx. **	Furnace external dim. WxHxL mm	Nominal Max. Power (W)
_D2.6/L12-1200	1200 x 60	26x120x200	40	300x300x200	700
_D2.6/L18-1200	1200 x 60	26x180x280	80	300x300x260	800
_D2.6/L23-1200	1200 x 60	26x230x330	130	300x300x340	1000
_D3.8/L18-1200	1200 x 60	38x180x280	80	316x316x260	1000
_D3.8/L23-1200	1200 x 60	38x230x330	130	316x316x340	1200
_D5.2/L18-1200	1200 x 60	52x180x280	80	330x330x260	1200
_D5.2/L23-1200	1200 x 60	52x230x330	130	330x330x340	1600
_D5.2/L30-1200	1200 x 60	52x230x400	200	330x330x410	2000
_D6.4/L18-1200	1200 x 60	64x180x280	80	340x340x260	1400
_D6.4/L23-1200	1200 x 60	64x230x330	130	340x340x340	1800
_D7.8/L23-1200	1200 x 60	78x230x330	130	355x355x340	2000

* Furnace working with no load and both ends closed

** Simulated indicative data. Valid for dense alumina process reactor fit to furnace diameter and with both ends plugged. Actual performance may vary depending on orientation, load mass and placement, reactor size and process gas flow existence.

Ordering example:

- RCT-BW1-O_D5.2/L30-1200: This Part Number includes one RCT-BW1-O-1200 family furnace having 52mm internal diameter, 300mm heated zone and is not hinged.

- To order only the furnace add at the end of the part number the suffix “Single”, e.g. RCT-BW1-O- D5.2/L23-1200_Single.

 HELLENIC PRODUCT.

Contact details:

Ath. Stagiriti 7- Pilea, Thessaloniki Greece, 55534

tel. 0030 2310 942346, fax. 0030 2310 942336

e-mail: info@thermansys.com

www.thermansys.com

Information and data contained in this document was considered correct at the time of publication.

Thermansys® is reserving the right to make modifications as a result of design improvements.